

Anisotropic multilevel stabilization of convection-diffusion problems

Claudio Canuto

<http://calvino.polito.it/~ccanuto>



DIPARTIMENTO DI MATEMATICA
POLITECNICO DI TORINO
CORSO DUCA DEGLI ABRUZZI 24
10129, TORINO, ITALY

References

- S.Bertoluzza, C.C., A.Tabacco, *Appl. Math. Lett.*, **13** (2000)
- S.Bertoluzza, C.C., A.Tabacco, *SINUM*, **38** (2000)
- C.C., *Computing*, **61** (2001)
- C.C., A.Tabacco, *East-West J. Numer. Anal.*, **38** (2001)
- S.Berrone, in preparation

Convection-diffusion equation

$$\begin{cases} -\nu\Delta u + \mathbf{a} \cdot \nabla u + bu = f & \text{in } \Omega, \\ u = \varphi, & \text{on } \partial\Omega \end{cases}$$

$\Omega \subset \mathbb{R}^n$ ($n = 2, 3$) region in the plane or in the space crossed by a fluid (river or lake)

$\mathbf{a} = \mathbf{a}(x)$ Eulerian velocity of the moving particle which is in x (stationary motion)

$u = u(x)$ concentration of a liquid pollution which pours in the water

The concentration u depends on

a) diffusion: $-\nu\Delta u$, ν (small) diffusion parameter

b) convection: $\mathbf{a} \cdot \nabla u$

c) reaction: bu

Remark. .

- $\frac{\|\mathbf{a}(x)\|}{\nu} \ll 1$ *dominant diffusion*
- $\frac{\nu}{\|\mathbf{a}(x)\|} \ll 1$ *dominant convection*
- *If $\nu \rightarrow 0^+$, we have a singularly perturbed problem*

Model problem

Let us consider the model convection-diffusion problem

$$\begin{cases} Lu := -\nu\Delta u + \mathbf{a} \cdot \nabla u + bu = f & \text{in } \Omega, \\ u = 0, & \text{on } \partial\Omega, \end{cases}$$

where

- $\Omega \subset \mathbb{R}^n$ is a bounded Lipschitz domain
- $\mathbf{a} \in (W^{1,\infty}(\Omega))^n$
- $b \in L^\infty(\Omega)$, $f \in L^2(\Omega)$
- $-\frac{1}{2}\nabla \cdot \mathbf{a} + b \geq \gamma$ a.e. in Ω , for some constant $\gamma > 0$
- $\nu \ll 1$, $\|\mathbf{a}\|_{L^\infty(\Omega)} \sim 1$, $\gamma \sim 1$

We denote by

$$Dw := \mathbf{a} \cdot \nabla w$$

the *streamline derivative* of the function w in Ω .

Variational formulation

Let

$$\begin{cases} A : H_0^1(\Omega) \times H_0^1(\Omega) \rightarrow \mathbb{R}, \\ A(w, v) := \nu(\nabla w, \nabla v) + (Dw, v) + (bw, v). \end{cases}$$

Then, the model problem is formulated variationally as

$$\begin{cases} \text{find } u \in H_0^1(\Omega) \text{ such that} \\ A(u, v) = (f, v) \quad \forall v \in H_0^1(\Omega). \end{cases}$$

This problem has a unique solution thanks to the Lax-Milgram theorem applied to the Hilbert space $V = H_0^1(\Omega)$ endowed with the energy norm

$$\|v\|_V = \left(\|v\|_{L^2(\Omega)}^2 + \nu \|\nabla v\|_{L^2(\Omega)}^2 \right)^{1/2}.$$

Theorem. (*Lax-Milgram*) Let V be a Hilbert space with norm $\|\cdot\|_V$ and let $A : V \times V \rightarrow \mathbb{R}$ be a bilinear form such that

a) A is continuous, i.e., $\exists \alpha_1 > 0$ such that

$$|A(w, v)| \leq \alpha_1 \|w\|_V \|v\|_V, \quad \forall w, v \in V;$$

b) A is coercive, i.e., $\exists \alpha_2 > 0$ such that

$$|A(w, w)| \geq \alpha_2 \|w\|_V^2, \quad \forall w \in V.$$

Finally, let $F \in V'$. Then the problem

$$A(u, v) = F(v), \quad \forall v \in V$$

has a unique solution $u \in V$ satisfying

$$\|u\|_V \leq \alpha_2^{-1} \|F\|_{V'}.$$

Lax-Milgram conditions

$$A(w, v) := \nu(\nabla w, \nabla v) + (Dw, v) + (bw, v)$$

a) Continuity

$$\begin{aligned} |\nu(\nabla w, \nabla v)| &\leq \nu \|\nabla w\|_{L^2(\Omega)} \|\nabla v\|_{L^2(\Omega)} \\ |(Dw, v)| &\leq \|\mathbf{a}\|_{(L^\infty(\Omega))^n} \|\nabla w\|_{L^2(\Omega)} \|v\|_{L^2(\Omega)} \\ &\lesssim \frac{1}{\sqrt{\nu}} \sqrt{\nu} \|\nabla w\|_{L^2(\Omega)} \|v\|_{L^2(\Omega)} \\ |(bw, v)| &\leq \|b\|_{L^\infty(\Omega)} \|w\|_{L^2(\Omega)} \|v\|_{L^2(\Omega)} \\ &\lesssim \|w\|_{L^2(\Omega)} \|v\|_{L^2(\Omega)} \end{aligned}$$

thus

$$\begin{aligned} |A(w, v)| &\leq \frac{1}{\sqrt{\nu}} \left(\|w\|_{L^2(\Omega)}^2 + \nu \|\nabla w\|_{L^2(\Omega)}^2 \right)^{1/2} \cdot \\ &\quad \left(\|v\|_{L^2(\Omega)}^2 + \nu \|\nabla v\|_{L^2(\Omega)}^2 \right)^{1/2} \end{aligned}$$

and

$$\alpha_1 \asymp \frac{1}{\sqrt{\nu}}$$

b) Coercivity

$$\begin{aligned} A(w, w) &\geq \nu \|\nabla w\|_{L^2(\Omega)}^2 + \gamma \|w\|_{L^2(\Omega)}^2 \\ &\gtrsim \|w\|_{L^2(\Omega)}^2 + \nu \|\nabla w\|_{L^2(\Omega)}^2 \end{aligned}$$

thus

$$\alpha_2 \asymp 1$$

Bad consequences on numerical discretization

Ω bounded polygonal domain, decomposed into non-overlapping 'elements' E (triangles, tetrahedrons, ...) of diameter $\asymp h$;
 $\mathcal{P}_m(E)$ space of polynomials of degree $\leq m$ on E .

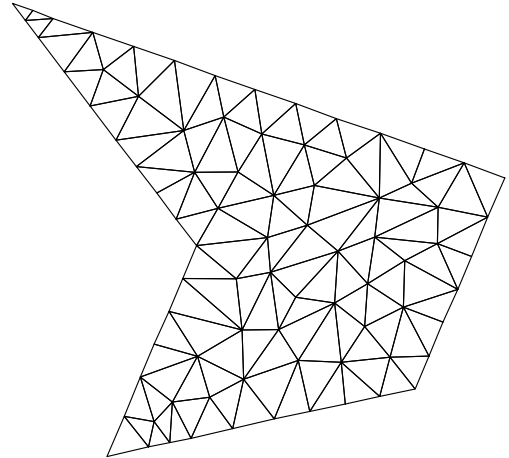

$$V = H_0^1(\Omega) \quad V_h = \{v \in V : v|_E \in \mathcal{P}_m(E), \forall E\}$$

Galerkin approximation:

$$\begin{cases} \text{find } u_h \in V_h \subset V \text{ such that} \\ A(u_h, v_h) = (f, v_h) \quad \forall v_h \in V_h \end{cases}$$

Error estimate:

$$\|u - u_h\|_V \leq \frac{1}{\sqrt{\nu}} \inf_{v_h \in V_h} \|u - v_h\|_V$$

\Rightarrow Large error $\|u - u_h\|_V$ unless $\inf_{v_h \in V_h} \|u - v_h\|_V \ll \sqrt{\nu}$

\Rightarrow Spurious oscillations (unless $h \ll \sqrt{\nu}$ in FEM)

Numerical Example

$$\begin{cases} -\nu\Delta u + \mathbf{a} \cdot \nabla u = 0 & \text{in } \Omega \\ u = g & \text{on } \Omega \end{cases}$$

with

$$\mathbf{a} = (1, 2)^T \quad \nu = 10^{-3}$$

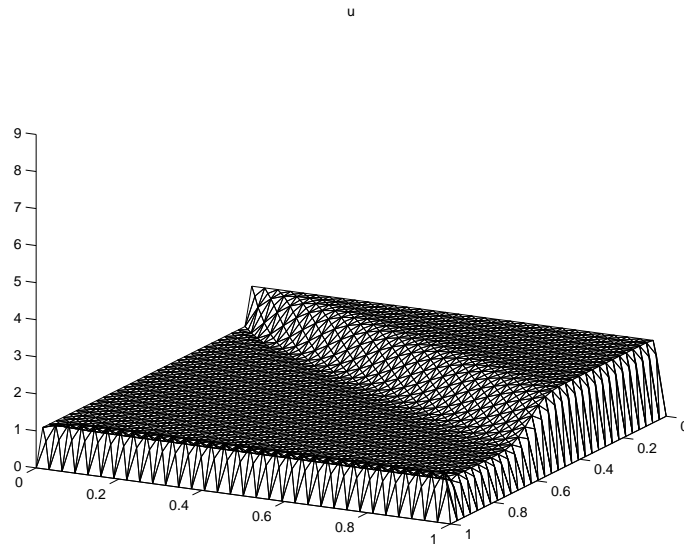

Exact solution

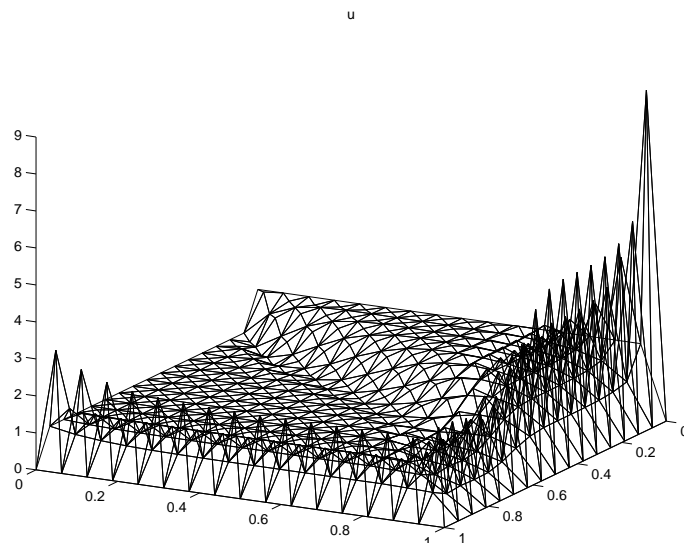

Galerkin solution

SUPG Streamline Upwind Petrov Galerkin stabilization (Hughes '82)

$$\left\{ \begin{array}{l} \text{find } u_h \in V_h \subset V \text{ such that} \\ A(u_h, v_h) + \llbracket Lu_h, Dv_h \rrbracket_h = (f, v_h) + \llbracket f, Dv_h \rrbracket_h \quad \forall v_h \in V_h \end{array} \right.$$

where

$$\llbracket \varphi, \psi \rrbracket_h = \sum_E \tau_E \int_E \varphi \psi$$

with

$$\tau_E = \begin{cases} \frac{h_E}{\|a\|_{L^\infty(E)}} & \text{if } \mathbb{P}e_\lambda > 1, \\ \frac{h_E^2}{\nu} & \text{if } \mathbb{P}e_\lambda \leq 1, \end{cases}$$

$$\mathbb{P}e_\lambda = \frac{h_E \|a\|_{L^\infty(E)}}{\nu}$$

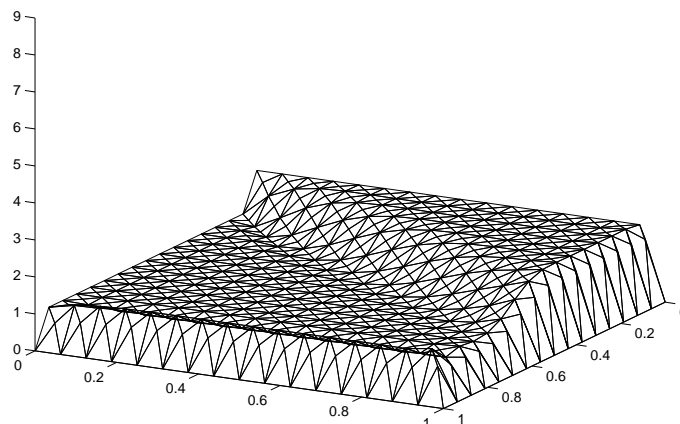

Stabilized solution

Ultimate goal

Define an equivalent problem

$$\begin{cases} \text{find } u \in H_0^1(\Omega) \text{ such that} \\ \mathcal{A}(u, v) = \mathcal{F}(v) \quad \forall v \in H_0^1(\Omega) \end{cases}$$

such that, for a suitable norm $\|\cdot\|_V$, one has

$$\mathcal{A}(w, w) \gtrsim \|w\|_V^2, \quad \forall w \in H_0^1(\Omega)$$

$$|\mathcal{A}(w, v)| \lesssim \|w\|_V \|v\|_V, \quad \forall w, v \in H_0^1(\Omega)$$

with the constants independent of ν .

For a standard (so called Galerkin) approximation $u_h \in V_h$, this would imply

$$\|u - u_h\|_V \asymp \inf_{v_h \in V_h} \|u - v_h\|_V$$

and

$$\|u - u_h\|_V \asymp \|f - Lu_h\|_{V'}.$$

Approach by stabilization

$$\mathcal{A}(w, v) := A(w, v) + \llbracket Lw, Lv \rrbracket_*$$

$$\mathcal{F}(v) := (f, v) + \llbracket f, Lv \rrbracket_*.$$

Stabilized variational problem

We denote by $\mathcal{X}^{1/2}(\Omega)$ the space $H_0^1(\Omega)$ equipped with the norm

$$\|v\|_{\mathcal{X}^{1/2}(\Omega)} := \left(\|v\|_{L^2(\Omega)}^2 + \nu \|\nabla v\|_{L^2(\Omega)}^2 + \llbracket Lv \rrbracket_*^2 \right)^{1/2}.$$

We define the continuous bilinear form

$$\begin{cases} \mathcal{A} : \mathcal{X}^{1/2}(\Omega) \times \mathcal{X}^{1/2}(\Omega) \rightarrow \mathbb{R}, \\ \mathcal{A}(w, v) := A(w, v) + \llbracket Lw, Lv \rrbracket_* \end{cases}$$

and the continuous linear form

$$\begin{cases} \mathcal{F} : \mathcal{X}^{1/2}(\Omega) \rightarrow \mathbb{R}, \\ \mathcal{F}(v) := (f, v) + \llbracket f, Lv \rrbracket_*. \end{cases}$$

The stabilized variational formulation of the model problem is:

$$\begin{cases} \text{find } u \in \mathcal{X}^{1/2}(\Omega) \text{ such that} \\ \mathcal{A}(u, v) = \mathcal{F}(v), \quad \forall v \in \mathcal{X}^{1/2}(\Omega). \end{cases}$$

Anisotropic Model problem

We consider the model problem:

$$\begin{cases} Lu := -\nu\Delta u + \mathbf{a} \cdot \nabla u + bu = f & \text{in } \Omega, \\ u = 0, & \text{on } \partial\Omega. \end{cases}$$

where now:

- $\Omega = (0, 1)^n$
- $\mathbf{a} = (a, 0, \dots, 0)$, with $a \in W^{1,\infty}(\Omega)$

In this particular case, we have

$$Dw = \mathbf{a} \cdot \nabla w = a \partial_{x_1} w.$$

Anisotropic Sobolev spaces

Let $I = (0, 1)$ and let $\{X^s(I)\}_{s \geq 0}$ be either

$$X^s(I) := H^s(I), \quad \text{or}$$

$$X^s(I) := \mathcal{H}^s(I) =$$

$$= \begin{cases} H^s(I) & \text{if } 0 \leq s < 1/2, \\ H_{00}^{1/2}(I) = [L^2(I), H_0^1(I)]_{1/2} & \text{if } s = 1/2, \\ H_0^s(I) & \text{if } 1/2 < s < 3/2, \\ H^s(I) \cap H_0^1(I) & \text{if } s \geq 3/2. \end{cases}$$

We define spaces of functions in Ω having different regularity in each coordinate direction.

We consider functions which are more regular along the first coordinate direction:

$$X^{(s,0)}(\Omega) := X^s(I) \otimes L^2(I^{n-1}).$$

We have

$$X^{(s,0)}(\Omega) = L^2(I^{n-1}, X^s(I));$$

hence,

$$\|v\|_{X^{(s,0)}(\Omega)} = \left(\int_{I^{n-1}} \|v(\cdot, x')\|_{X^s(I)} dx' \right)^{1/2}.$$

Furthermore, for $s_1, s_2 \geq 0$, $0 < \theta < 1$, we set

$$s = (1 - \theta)s_1 + \theta s_2;$$

then

$$X^s(I) = [X^{s_1}(I), X^{s_2}(I)]_\theta$$

implies

$$X^{(s,0)}(\Omega) = [X^{(s_1,0)}(\Omega), X^{(s_2,0)}(\Omega)]_\theta.$$

Concerning the duals, we set

$$X^{-s}(I) := (X^s(I))'$$

and

$$X^{(-s,0)}(\Omega) := (X^{(s,0)}(\Omega))';$$

thus, we have

$$X^{(-s,0)}(\Omega) = X^{-s}(I) \otimes L^2(I^{n-1}).$$

Wavelets bases

Bases in 1D

Suppose we have biorthogonal wavelet bases

$$\{\psi_{\lambda_i}^{(i)}, \tilde{\psi}_{\lambda_i}^{(i)}\}_{\lambda_i \in \Lambda^{(i)}} \quad \text{in } L^2(I), \quad i = 1, \dots, n.$$

We recall that any $v \in L^2(I)$ can be written as

$$v = \sum_{\lambda_i \in \Lambda^{(i)}} (v, \tilde{\psi}_{\lambda_i}^{(i)}) \psi_{\lambda_i}^{(i)}$$

with

$$\|v\|_{L^2(I)} \asymp \left(\sum_{\lambda_i \in \Lambda^{(i)}} |(v, \tilde{\psi}_{\lambda_i}^{(i)})|^2 \right)^{1/2},$$

and any $v^* \in (L^2(I))' = L^2(I)$ is represented by

$$v^* = \sum_{\lambda_i \in \Lambda^{(i)}} (v^*, \psi_{\lambda_i}^{(i)}) \tilde{\psi}_{\lambda_i}^{(i)}$$

with

$$\|v^*\|_{L^2(I)} \asymp \left(\sum_{\lambda_i \in \Lambda^{(i)}} |(v^*, \psi_{\lambda_i}^{(i)})|^2 \right)^{1/2}.$$

Moreover, for $i = 1$, we suppose that for $0 \leq s < s^*$,

$$v \in X^s(I) \iff \sum_{\lambda_1 \in \Lambda^{(1)}} 2^{2|\lambda_1|s} |(v, \tilde{\psi}_{\lambda_1}^{(1)})|^2 < +\infty$$

with

$$v = \sum_{\lambda_1 \in \Lambda^{(1)}} (v, \tilde{\psi}_{\lambda_1}^{(1)}) \psi_{\lambda_1}^{(1)}$$

and

$$\|v\|_{X^s(I)} \asymp \left(\sum_{\lambda_1 \in \Lambda^{(1)}} 2^{2|\lambda_1|s} |(v, \tilde{\psi}_{\lambda_1}^{(1)})|^2 \right)^{1/2};$$

on the other hand,

$$v^* \in X^{-s}(I) \iff v^* = \sum_{\lambda_1 \in \Lambda^{(1)}} \tilde{v}_{\lambda_1} \tilde{\psi}_{\lambda_1}^{(1)}$$

with

$$\sum_{\lambda_1 \in \Lambda^{(1)}} 2^{-2|\lambda_1|s} |\tilde{v}_{\lambda_1}|^2 < +\infty, \quad \tilde{v}_{\lambda_1} = \langle v^*, \psi_{\lambda_1}^{(1)} \rangle.$$

Moreover,

$$\|v^*\|_{X^{-s}(I)} \asymp \left(\sum_{\lambda_1 \in \Lambda^{(1)}} 2^{-2|\lambda_1|s} |\tilde{v}_{\lambda_1}|^2 \right)^{1/2}.$$

Wavelets on the unit interval

see S.Grivet-Talocia, A.T., M³AS 2000

Boundary adapted spline wavelet bases $\{\psi_{jk}\}_{j \geq 0, 0 \leq k \leq 2^j - 1}$.

We set $\lambda = (j, k)$, $|\lambda| = j$, $\psi_\lambda = \psi_{jk}$.

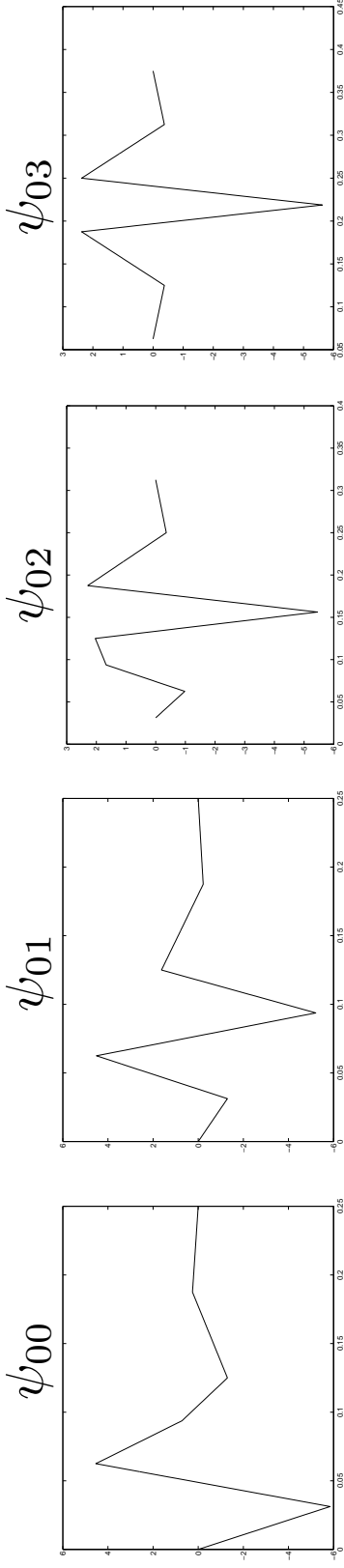

Figure 1: Primal border wavelets obtained from a B-spline multiresolution with $L = 2$ and $\tilde{L} = 4$.

Tensor product bases

We set

$$\lambda = (\lambda_1, \lambda_2, \dots, \lambda_n) \in \Lambda := \Lambda^{(1)} \times \Lambda^{(2)} \times \dots \times \Lambda^{(n)},$$

and we define the tensor product anisotropic biorthogonal wavelet bases in $L^2(\Omega)$ as

$$\psi_\lambda := \psi_{\lambda_1}^{(1)} \otimes \dots \otimes \psi_{\lambda_n}^{(n)}, \quad \tilde{\psi}_\lambda := \tilde{\psi}_{\lambda_1}^{(1)} \otimes \dots \otimes \tilde{\psi}_{\lambda_n}^{(n)}.$$

Then, for each $0 \leq s < s^*$,

$$v \in X^{(s,0)}(\Omega) \iff \sum_{\lambda \in \Lambda} 2^{2|\lambda_1|s} |(v, \tilde{\psi}_\lambda)_{L^2(\Omega)}|^2 < +\infty$$

with

$$v = \sum_{\lambda \in \Lambda} (v, \tilde{\psi}_\lambda)_{L^2(\Omega)} \psi_\lambda$$

and

$$\|v\|_{X^{(s,0)}(\Omega)} \asymp \left(\sum_{\lambda \in \Lambda} 2^{2|\lambda_1|s} |(v, \tilde{\psi}_\lambda)_{L^2(\Omega)}|^2 \right)^{1/2}.$$

Similarly $v^* \in X^{(-s,0)}(\Omega)$ if and only if

$$v^* = \sum_{\lambda \in \Lambda} \tilde{v}_\lambda \tilde{\psi}_\lambda, \quad \sum_{\lambda \in \Lambda} 2^{-2|\lambda_1|s} |\tilde{v}_\lambda|^2 < +\infty;$$

moreover,

$$\|v^*\|_{X^{(-s,0)}(\Omega)} \asymp \left(\sum_{\lambda \in \Lambda} 2^{-2|\lambda_1|s} |\tilde{v}_\lambda|^2 \right)^{1/2}, \quad \tilde{v}_\lambda = \langle v^*, \psi_\lambda \rangle.$$

Next, for any multi-index $\mathbf{s} = (s_1, \dots, s_n) \geq 0$ we define

$$X^{\mathbf{s}}(\Omega) = X^{(s_1, \mathbf{0})}(\Omega) \cap X^{(\mathbf{0}, s_2, \dots, 0)}(\Omega) \cap \dots \cap X^{(\mathbf{0}, s_n)}(\Omega)$$

equipped with the norm

$$\|v\|_{X^{\mathbf{s}}(\Omega)}^2 = \|v\|_{X^{(s_1, \mathbf{0})}(\Omega)}^2 + \dots + \|v\|_{X^{(\mathbf{0}, s_n)}(\Omega)}^2.$$

Concerning the wavelet bases, one has

$$\|v\|_{X^{\mathbf{s}}(\Omega)}^2 \asymp \sum_{\lambda \in \Lambda} (2^{2|\lambda_1|s_1} + \dots + 2^{2|\lambda_n|s_n}) |(v, \tilde{\psi}_\lambda)|^2,$$

and

$$\|v^*\|_{X^{-\mathbf{s}}(\Omega)}^2 \asymp \sum_{\lambda \in \Lambda} (2^{2|\lambda_1|s_1} + \dots + 2^{2|\lambda_n|s_n})^{-1} |\langle v^*, \psi_\lambda \rangle|^2.$$

In particular, we have

$$\begin{aligned} \|v\|_{H_0^1(\Omega)}^2 &\asymp \sum_{\lambda \in \Lambda} \left(\sum_{i=1}^n 2^{2|\lambda_i|} \right) |(v, \tilde{\psi}_\lambda)|^2, \\ \|v^*\|_{H^{-1}(\Omega)}^2 &\asymp \sum_{\lambda \in \Lambda} \left(\sum_{i=1}^n 2^{2|\lambda_i|} \right)^{-1} |\langle v^*, \psi_\lambda \rangle|^2, \end{aligned} \quad (1)$$

and

$$\begin{aligned} \|v\|_{X(\frac{1}{2}, \mathbf{0})(\Omega)}^2 &\asymp \sum_{\lambda \in \Lambda} 2^{|\lambda_1|} |(v, \tilde{\psi}_\lambda)|^2, \\ \|v^*\|_{X(-\frac{1}{2}, \mathbf{0})(\Omega)}^2 &\asymp \sum_{\lambda \in \Lambda} 2^{-|\lambda_1|} |\langle v^*, \psi_\lambda \rangle|^2. \end{aligned} \quad (2)$$

We will consider the right-hand side of (1) as the Hilbertian norm associated with the inner product in $H^{-1}(\Omega)$

$$\sum_{\lambda \in \Lambda} \left(\sum_{i=1}^n 2^{2|\lambda_i|} \right)^{-1} \langle w^*, \psi_\lambda \rangle \langle v^*, \psi_\lambda \rangle;$$

and the right-hand side of (2) as associated with the inner product in $X(-\frac{1}{2}, \mathbf{0})(\Omega)$

$$\sum_{\lambda \in \Lambda} 2^{-|\lambda_1|} \langle w^*, \psi_\lambda \rangle \langle v^*, \psi_\lambda \rangle.$$

Anisotropic multilevel Péclet number

We set $S_\lambda = \text{supp } \psi_\lambda \cup \text{supp } \tilde{\psi}_\lambda$.

For each $\lambda \in \Lambda$, we define the *anisotropic multilevel* Péclet number as

$$\mathbb{P}e_\lambda := \frac{\|a\|_{L^\infty(S_\lambda)} 2^{-|\lambda_1|}}{\nu} \cdot \frac{2^{2|\lambda_1|}}{\sum_{i=1}^n 2^{2|\lambda_i|}}.$$

Next, let us define the weights

$$\begin{aligned} \tau_\lambda &= \begin{cases} \frac{2^{-|\lambda_1|}}{\|a\|_{L^\infty(S_\lambda)}} & \text{if } \mathbb{P}e_\lambda > 1, \\ \frac{(\sum_{i=1}^n 2^{2|\lambda_i|})^{-1}}{\nu} & \text{if } \mathbb{P}e_\lambda \leq 1. \end{cases} \\ &= \min \left(\frac{2^{-|\lambda_1|}}{\|a\|_{L^\infty(S_\lambda)}}, \frac{(\sum_{i=1}^n 2^{2|\lambda_i|})^{-1}}{\nu} \right). \end{aligned}$$

Let us introduce the inner product and the norm in $H^{-1}(\Omega)$

$$[[w^*, v^*]]_* = \sum_{\lambda \in \Lambda} \tau_\lambda \langle w^*, \psi_\lambda \rangle \langle v^*, \psi_\lambda \rangle$$

$$[[v^*]]_* = [[v^*, v^*]]_*^{1/2}.$$

Note that the right-hand side is finite:

indeed, one has

$$\left| \sum_{\lambda \in \Lambda} \tau_{\lambda} \langle w^*, \psi_{\lambda} \rangle \langle v^*, \psi_{\lambda} \rangle \right| \lesssim \nu^{-1} \|w^*\|_{H^{-1}(\Omega)} \|v^*\|_{H^{-1}(\Omega)}.$$

The bilinear form $[[w^*, v^*]]_*$ is a multiscale **variable order** inner product in $H^{-1}(\Omega)$:

- large scale components ($Pe_{\lambda} > 1$) are weighted as in the $X^{(-\frac{1}{2}, 0)}(\Omega)$ -inner product
- small scale components ($Pe_{\lambda} \leq 1$) are weighted as in the $H^{-1}(\Omega)$ -inner product.

Coercivity estimate

Proposition. *The form \mathcal{A} is coercive on $\mathcal{X}^{1/2}(\Omega)$.*

Indeed, for all $w \in \mathcal{X}^{1/2}(\Omega)$,

$$\begin{aligned} \mathcal{A}(w, w) &= A(w, w) + \llbracket Lw \rrbracket_*^2 \\ &\geq \nu \|\nabla w\|_{L^2(\Omega)}^2 + \gamma \|w\|_{L^2(\Omega)}^2 + \llbracket Lw \rrbracket_*^2 \\ &\geq \min(1, \gamma) \|w\|_{\mathcal{X}^{1/2}(\Omega)}^2. \end{aligned}$$

Remark. *If $a^{-1} \in L^\infty(\Omega)$, then*

$$\begin{aligned} \|w\|_{\mathcal{X}^{1/2}(\Omega)} &= \left(\|v\|_{L^2(\Omega)}^2 + \nu \|\nabla v\|_{L^2(\Omega)}^2 + \llbracket Lv \rrbracket_*^2 \right)^{1/2} \\ &\asymp \left(\|v\|_{L^2(\Omega)}^2 + \nu \|\nabla v\|_{L^2(\Omega)}^2 + \llbracket Dv \rrbracket_*^2 \right)^{1/2} \\ &\gtrsim \|Dv\|_{\mathcal{H}^{(-\frac{1}{2}, 0)}(\Omega)} \\ &\gtrsim \|v\|_{H^{(\frac{1}{2}, 0)}(\Omega)}. \end{aligned}$$

Continuity estimates

Proposition. *The following estimate holds*

$$\forall w, v \in \mathcal{X}^{1/2}(\Omega)$$

$$|\mathcal{A}(w, v)| \lesssim \left(\|w\|_{\mathcal{X}^{1/2}(\Omega)} + \|w\|_{\mathcal{H}^{(\frac{1}{2}, 0)}(\Omega)} \right) \|v\|_{\mathcal{X}^{1/2}(\Omega)}.$$

Recall that

$$\mathcal{H}^{(\frac{1}{2}, 0)}(\Omega) = H_{00}^{1/2}(I) \otimes L^2(I^{n-1})$$

and

$$\|w\|_{H_{00}^{1/2}(I)} \asymp \|w\|_{H^{1/2}(I)} + \|\rho^{-1/2}w\|_{L^2(\Omega)}$$

where $\rho(x) = \text{dist}(x, \partial I)$.

Proposition. *Assume $a^{-1} \in L^\infty(\Omega)$. Then*

$$\forall w, v \in \mathcal{X}^{1/2}(\Omega)$$

$$|\mathcal{A}(w, v)| \lesssim \left(\|w\|_{\mathcal{X}^{1/2}(\Omega)} + \|\rho^{-1/2}w\|_{L^2(\Omega)} \right) \|v\|_{\mathcal{X}^{1/2}(\Omega)}.$$

Remark. *The estimate*

$$|\mathcal{A}(w, v)| \lesssim \|w\|_{\mathcal{X}^{1/2}(\Omega)} \|v\|_{\mathcal{X}^{1/2}(\Omega)}$$

is false.

Indeed, already in 1D and for $a \equiv 1$, the bound

$$|\langle w', v \rangle| \lesssim \|w'\|_{(H_{00}^{1/2}(I))'} \|v'\|_{(H_{00}^{1/2}(I))'}$$

would imply

$$\|w\|_{H_{00}^{1/2}(I)} \lesssim \|w\|_{H^{1/2}(I)}$$

which is false.

Some useful (and known) facts about the differential operator

$$d_x = \frac{d}{dx}$$

on the interval $I = (0, 1)$.

Property. $d_x \in \mathcal{L}(H^{1/2}(I), (H_{00}^{1/2}(I))')$.

Property. $d_x \in \mathcal{L}(H_{00}^{1/2}(I), H^{-1/2}(I))$.

Property. For all $v, w \in H_{00}^{1/2}(I)$,

$$|_{H^{-1/2}(I)} \langle d_x w, v \rangle_{H^{1/2}(I)}| \lesssim \|d_x w\|_{H^{-1/2}(I)} \|d_x v\|_{(H_{00}^{1/2}(I))'}$$

On the right hand side, v and w can be interchanged.

Remark. *The estimate*

$$|_{H^{-1/2}(I)} \langle d_x v, w \rangle_{H^{1/2}(I)}| \lesssim \|d_x v\|_{(H_{00}^{1/2}(I))'}, \|d_x w\|_{(H_{00}^{1/2}(I))'} \quad \forall$$

is false. Indeed, it would imply

$$\|v\|_{H_{00}^{1/2}(I)} \lesssim \|v\|_{H^{1/2}(I)}, \quad \forall v \in H_{00}^{1/2}(I).$$

Finite dimensional approximation

Let $\{V_h\}_{h>0}$ be a family of subspaces of $H_0^1(\Omega)$.

We consider the Galerkin approximation of the infinite dimensional stabilized formulation

$$\begin{cases} \text{find } u_h \in V_h \text{ such that} \\ \mathcal{A}(u_h, v_h) = \mathcal{F}(v_h), \quad \forall v_h \in V_h. \end{cases}$$

Stability

$$\|u\|_{\mathcal{X}^{1/2}(\Omega)} \lesssim \|f\|_{\mathcal{X}^{-1/2}(\Omega)}.$$

Moreover, if $a^{-1} \in L^\infty(\Omega)$, then

$$\|u_h\|_{L^2(\Omega)} + \sqrt{\nu} \|\nabla u_h\|_{L^2(\Omega)} + \|u_h\|_{H^{(\frac{1}{2}, 0)}(\Omega)} \lesssim \|f\|_{L^2(\Omega)}.$$

A priori error bound

$$\|u - u_h\|_{\mathcal{X}^{1/2}(\Omega)} \lesssim \inf_{w_h \in V_h} \|u - w_h\|_{\tilde{\mathcal{X}}^{1/2}(\Omega)}.$$